

CUSTOMIZED SHIPPING & STORAGE SOLUTIONS

For your high-value & hazmat goods

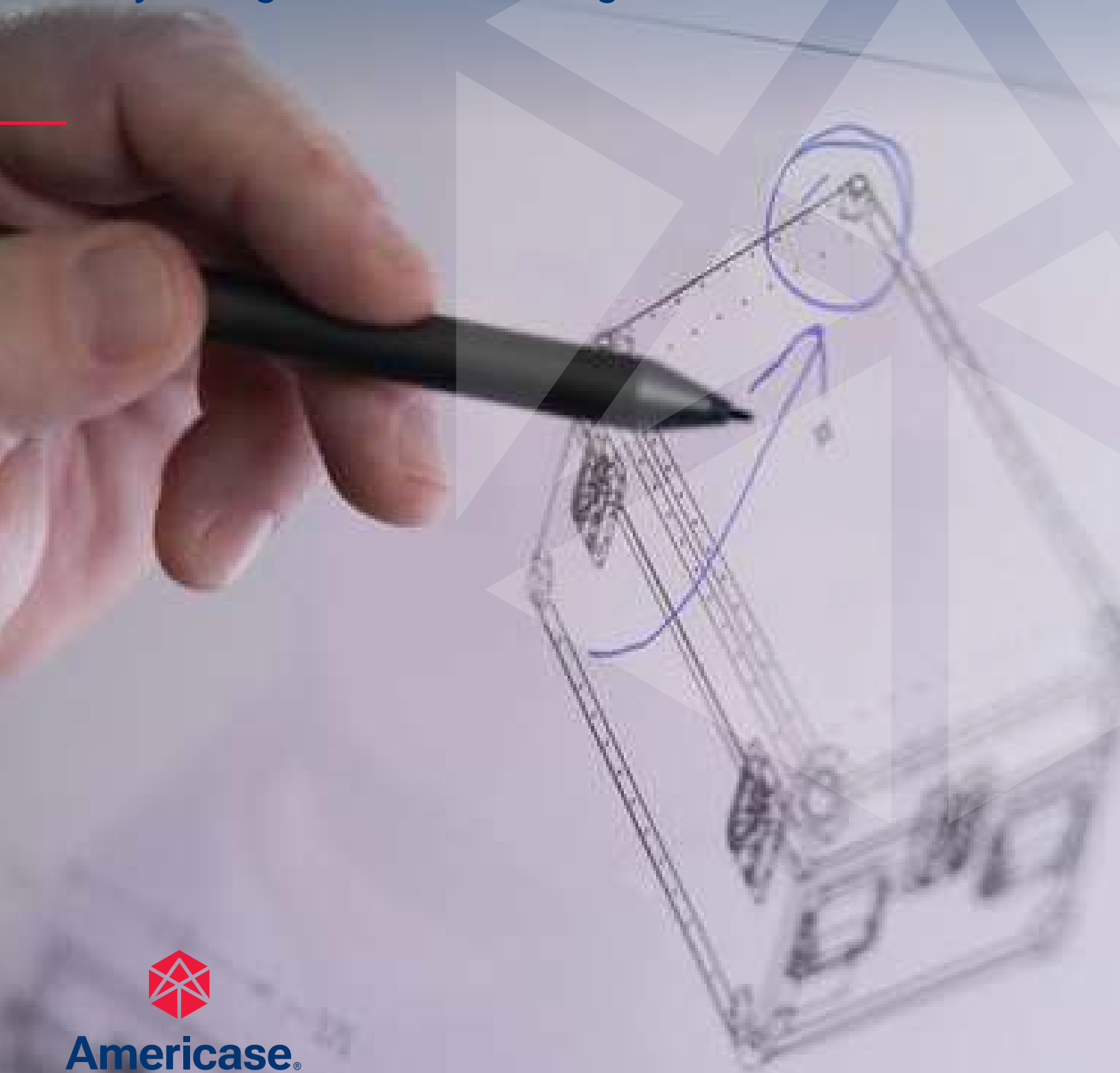

Americase®

Your Custom Case Design Partner

At Americase, we understand that each business has unique needs and requirements when it comes to safe transportation and storage for their products. With our three-step consultation process, we gain an in-depth understanding of your unique requirements so we can develop a smart, efficient solution built to meet your specific needs and challenges.

Our in-house team of engineers and manufacturers understands that the typical practices aren't enough for your high-value or dangerous goods, so we bring a smart and practical approach to each project and ensure that superior functionality is the standard with every case.



photo: NASA/Kim Shiflett



Discovery

In the first step of our consultation process, our team will take time to learn everything we can about your project and the needs you have for your custom shipping cases. This includes:

- What type of product you need to safely ship and/or securely store
- The environment and factors that go into the shipping and/or storage of your product
- Your performance criteria
- The modes of transportation involved
- Your ideal delivery timeline
- The quantity of cases you need and your budget



Analysis

Once we're familiar with your project needs, we will recommend an on-site evaluation so our team can gain a full understanding of your specific requirements and uncover any additional considerations. This step is essential because the insights we discover will help us design the case that delivers the superior functionality and solution your challenge requires. Once on-site, our experts will analyze your circumstances to learn:

- Any applicable facility restrictions
- Storage requirements
- If any regulatory/compliance oversight considerations are at play
- Which specific handling or performance criteria need to be considered
- If you have any appearance requirements for branding or aesthetic purposes
- If it's necessary that we help you develop ROI for your use case



Solution Proposal

In this final step of our consultation, the Americase team will use the data we gathered during our Discovery and Analysis processes to develop a concept for your custom container solution. At this point, you will receive:

- An overview of your custom solution
- An estimate of the design, development, manufacturing, and deployment timeline
- A cost estimate, detailing the materials and processes involved in producing your unique solution

Containers Designed for Your Industry & Tested for Your Application

Countless industries rely on Americase to custom engineer cases for their unique shipping and storage needs, whether their products are uniquely shaped, fragile, or temperamental. We exhaustively test all cases at our in-house testing lab to ensure they meet all of the performance and regulatory requirements.

- Consumer Electronics
- Data Centers
- Automotive
- Airline & General Aviation
- Oil & Gas
- Power Tools
- Recreational Vehicles & Micromobility Devices
- Space & Exploration
- U.S. Military
- Medical Devices
- Semiconductors

Do you have a shipping or storage challenge? We can help.

Cases in Point

1

A major **defense contractor** partnered with Americase to design containers for safely transporting high-value, fragile, classified products. Their previous solution was too bulky and caused damage to internal frames.

Americase developed lightweight cases with removable wheels and other streamlined features. Rigorous testing, including drop, rain, and side impact, confirmed the cases' reliability. They passed all tests successfully and remain in use by the contractor.



2

A top **space and exploration** company turned to Americase to develop protective containers for their equipment and parts. After initially working with Americase, they opted for a local manufacturer to reduce shipping costs, but the local solutions proved unreliable, frequently breaking and damaging valuable cargo.

Americase was re-engaged to design custom containers, including heat shield cases, that passed all the rigorous industry testing. Impressed by the durability and performance of these solutions, the company continues to collaborate with Americase on other projects.

3

Airbus contacted Americase to develop safe and efficient containers to ship helicopter blades. Their existing packaging failed to protect the blades during transportation and storage, which resulted in helicopter blades damage due to forklift punctures, dropped cases, harsh environmental conditions, and more.

Americase engineered a durable, protective container solution made of double walled aluminum with an additional kickplate to prevent forklift punctures. The case design included innovative custom inserts to contain single or multiple blades. Exhaustive testing, including vibration, drop, and rain, ensured the blades inside remained safe even in the harshest conditions. The cases also helped streamline logistics with the versatile, reusable, stackable design. Airbus European division has since switched their packaging to the Americase solution. Americase solutions are now utilized at Bell, Leonardo, Kaman, Sikorsky, MD Helicopters, and others, as well as MRO companies.



4

A leading **defense contractor** needed a protective container solution to ship instruments essential to national defense. The product was shipped in five separate pieces, each requiring a specialized case tailored to its unique shape and characteristics.

Americase developed a durable five-case solution that secured each component inside its specific case. The cases were rigorously tested to ensure they can withstand even the harshest conditions, including the demanding vibration, rain, stacking and drop tests, which they passed with flying colors. The solution also added value with easy-to-use structure and lid for maximum operational efficiency, reducing handling time by over 50%. The company continues to purchase our protective cases.



WE START WITH INNOVATION



AMERICASE LLC
6200 N I-35
Waxahachie, TX 75165
United States

TOLL-FREE
800-972-2737

PHONE
972-937-3629

WEBSITE
www.americase.com

